

SPECIFICATIONS

Tubes	50 x 4 mm (1.97 x 0.16 in)
Braces	25 x 3 mm (0.98 x 0.12 in)
Alloy	EN AW-6082 T6

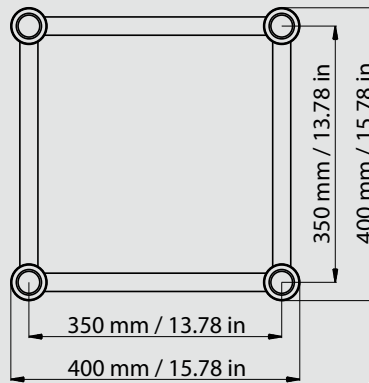

LOADING TABLES

		2 m	4 m	6 m	8 m	10 m	12 m	14 m	16 m	18 m	20 m
UDL [kg/m]		2126	1057	700	390	245	166	119	88	66	50
Deflection [mm]		0.9	7.2	24.3	43.5	68.1	98.3	134.2	175.8	221.8	267.2
CPL [kg]		4253	3197	2111	1561	1226	999	833	705	596	496
Deflection [mm]		1.4	8.7	19.6	35.1	55.2	80.2	110.1	145.4	184.6	225.5
TPL [kg]		2137	2136	1583	1171	920	749	625	529	447	372
Deflection [mm]		1.2	9.9	25	44.4	69.5	100.3	136.8	179.2	225.1	271.8
QPL [kg]		2137	2136	1583	1171	920	749	625	529	447	372
Deflection [mm]		1.1	9.2	23.2	41.4	64.9	93.8	128.1	168.2	212	256.7
		6.56 ft	13.12 ft	19.69 ft	26.25 ft	32.81 ft	39.37 ft	45.93 ft	52.49 ft	59.06 ft	65.62 ft
UDL [lbs/ft]		1428.61	710.27	470.38	262.07	164.63	111.55	79.96	59.13	44.35	33.60
Deflection [in]		0.04	0.28	0.96	1.71	2.68	3.87	5.28	6.92	8.73	10.52
CPL [lbs]		9376.26	7048.18	4653.96	3441.42	2702.87	2202.42	1836.45	1554.26	1313.96	1093.49
Deflection [in]		0.06	0.34	0.77	1.38	2.17	3.16	4.33	5.72	7.27	8.88
TPL [lbs]		4711.28	4709.07	3489.92	2581.61	2028.25	1651.26	1377.89	1166.25	985.47	820.12
Deflection [in]		0.05	0.39	0.98	1.75	2.74	3.95	5.39	7.06	8.86	10.70
QPL [lbs]		4711.28	4709.07	3489.92	2581.61	2028.25	1651.26	1377.89	1166.25	985.47	820.12
Deflection [in]		0.04	0.36	0.91	1.63	2.56	3.69	5.04	6.62	8.35	10.11

Loading tables are valid for static loads and spans with two supporting points. Spans must be supported at each end. Contact structural engineer if there are more supporting points applied or dynamic and wind loads involved.

STRAIGHT SEGMENT LENGTHS

Code	Length		Weight	
TT44-50	0.5 m	1.64 ft	6.98 kg	15.40 lbs
TT44-100	1 m	3.28 ft	11.85 kg	26.13 lbs
TT44-150	1.5 m	4.92 ft	16.29 kg	35.91 lbs
TT44-200	2 m	6.56 ft	20.58 kg	45.37 lbs
TT44-250	2.5 m	8.20 ft	24.97 kg	55.05 lbs
TT44-300	3 m	9.84 ft	29.72 kg	65.53 lbs
TT44-350	3.5 m	11.48 ft	34.20 kg	75.40 lbs
TT44-400	4 m	13.12 ft	38.58 kg	85.05 lbs
TT44-450	4.5 m	14.76 ft	42.72 kg	94.18 lbs
TT44-500	5 m	16.40 ft	47.80 kg	105.38 lbs

